

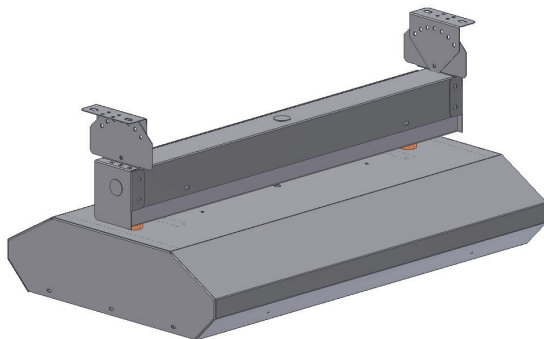

MTM

Models 'TH', 'THSS' and 'THA' Series 222,223,342,343,462,463 2 and 3 Lamp Units OVERHEAD ELECTRIC INFRARED HEATER

MODELS TH AND THSS



MODEL THA

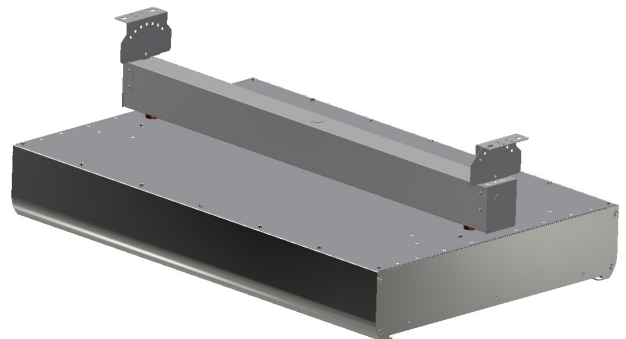

WARNING

IMPORTANT SAFETY INFORMATION INSIDE

- Serious injury or death possible
- Read, understand, and follow all safety information and instructions in this manual before using or servicing this product.
- Retain these instructions for future reference.

REFER TO
COMPLETE
INDEX OF
INFORMATION
ON
PAGE 2

TABLE OF CONTENTS

Warnings	Page 3
Important Instructions	Page 4
Specifications	Page 5
Installation Planning & Layout Design	Page 6
Application Guide	Page 7
Clearances to Combustibles	Page 8
Mounting Instructions	Page 9 & 10
Totally Exposed Outdoor Applications	Page 11
Lamp Installation & Replacement	Page 11
Electrical Wiring for Models 222, 342, & 462	Page 12
Electrical Wiring for Models 223, 343, & 463	Page 13
Maintenance, Troubleshooting	Page 14
Optional Recessed Mounting Frame Installation	Page 15
Optional Wire Guard Installation Models 'TH' and 'THSS'	Page 16
Optional Wire Guard Installation Models 'THA'	Page 17



ATTENTION:

The table to the right provides definitions of the signal words that can be found throughout this manual. These signal words are used to express the severity of the hazard at hand. The signal words are generally used in conjunction with safety symbols that correspond to the text for that particular hazard. As you read this manual, refer back to this table when you are unsure of the signal word definition.

SIGNAL WORD DEFINITIONS	
DANGER	DANGER indicates an imminently hazardous situation which, if not avoided, will result in death or serious injury.
WARNING	WARNING indicates a potentially hazardous situation which, if not avoided, could result in death or serious injury.
CAUTION	CAUTION indicates a potentially hazardous situation which, if not avoided, may result in minor or moderate injury.
CAUTION	CAUTION used without the safety alert symbol indicates a potentially hazardous situation which, if not avoided, may result in property damage.
As defined in ANSI Z535.4-2002	



WARNING

SAFETY INFORMATION

READ THIS MANUAL CAREFULLY before installing or servicing this product. Improper installation, operation, or maintenance can result in death, severe injury, or property damage!

NOT FOR INDOOR RESIDENTIAL USE!

FOR INDOOR COMMERCIAL/INDUSTRIAL USE.

FOR PROTECTED AND UNPROTECTED OUT-DOOR USE.

NOT FOR USE IN HAZARDOUS OR EXPLOSIVE ATMOSPHERES!

INSTALLATION AND SERVICE OF THESE PRODUCTS MUST BE CONDUCTED BY TRAINED PERSONNEL EXPERIENCED WITH ELECTRICAL EQUIPMENT.

CLEARANCES TO COMBUSTIBLES AS DOCUMENTED IN THIS MANUAL AND ON THE HEATER MUST BE MAINTAINED AT ALL TIMES!

Combustibles: Failure to maintain minimum clearances to combustible materials can result in serious fire hazard. Locations used for storage of combustible materials must have signs posted to specify maximum permissible stacking heights such that required clearances are maintained. These signs must be conspicuously located or adjacent to heater thermostats.

Vehicles: These heaters must be installed such that the minimum clearances described in this manual are maintained from vehicles parked below the heater.

Suspension: The use of appropriate mounting hardware (beam clamps, chains, rods, turnbuckles, etc.) are a must. The weight of the heater must be entirely supported from a permanent part of the building structure having adequate load characteristics.

Do not attach ductwork to this heater or attempt to use it as a make-up air heater. Such use voids the warranty and may create unsafe conditions.

Do not insert fingers or foreign objects into the heater. Do not block or tamper with the heater while it is in operation. Do not touch heater while it is in operation or just after it has been turned off, as some parts may be hot enough to cause injury.

Make certain that the power source conforms to the electrical requirements of the heater. Disconnect power before installing or servicing. If the power disconnect is out of sight, lock it in the open position and tag it to prevent unexpected application of power. Failure to do so could result in fatal electric shock.

WARNING: DO NOT DEPEND UPON A THERMOSTAT OR OTHER SWITCH AS THE SOLE MEANS OF DISCONNECTING POWER WHEN INSTALLING OR SERVICING THE HEATER. FOR CE APPLICATIONS AN ALL POLE DISCONNECT WITH CONTACT SEPARATION OF AT LEAST 3mm MUST BE USED. ALWAYS DISCONNECT BREAKER AS DESCRIBED ABOVE. FAILURE TO DO SO COULD RESULT IN FATAL ELECTRIC SHOCK.

This heater is intended **ONLY** for permanent installation in accordance with the National Electric Code (NEC), all applicable local codes and ordinances, and all sections of this manual. Any variance voids the warranty and may create unsafe conditions.

USE COPPER WIRING ONLY

Special attention must be given to any bonding* (grounding) information pertaining to this heater. To prevent the risk of electrocution, the heater must be securely and adequately bonded. This should be accomplished by connecting a conductor between the service panel and the green grounding screw provided on the heater. To ensure a proper bond, the bonding means must be tested by a qualified electrician.

Check branch voltage. Heaters should be operated at voltages no higher than the heating elements and the heater are designed for. (Lower voltages, however, pose no problem other than a loss of wattage). Heaters are not intended for process heating applications.

In cases where property damage may result from malfunction of the heater, a back-up system or a temperature alarm should be used.

*Bonding is the term that describes the completion of the electrical circuit back to its source, which allows a breaker or fuse to clear if a short occurs in the line.

IMPORTANT INSTRUCTIONS

1. Read all instructions before installing or using the heater
2. This heater is hot when in use. To avoid burns, do not let bare skin touch hot surfaces. Keep away from combustible materials at minimum, the following required distances.

CAUTION: DO NOT install closer than 24 inches to a vertical surface or 6 inches to a ceiling. Heaters MUST BE SEPARATED by more than 36 inches and 72 inches from any combustible surface in direct radiation path.

ATTENTION: NE PAS installer à moins de 24 pouces à une surface verticale ou 6 pouces à un plafond. Chauffe doivent être séparés par plus de 36 pouces et 72 pouces de toute surface combustible dans le chemin de rayonnement direct

- 3.
4. Extreme caution is necessary when any heater is used by or near children or invalids and whenever the heater is left operating and unattended.
5. Do not operate any heater after it malfunctions. Disconnect power at service panel and have heater inspected by a reputable electrician before reusing.
6. Do not use outdoors.
7. To disconnect heater, turn controls to off, and turn off power to heater circuit at the main disconnect panel (or operate internal disconnect switch if provided).
8. Do not insert or allow foreign objects to enter any ventilation or exhaust opening as this may cause an electric shock or fire, or damage to the heater.
9. To prevent a possible fire, do not block air intakes or exhaust in any manner.
10. A heater has hot and arcing or sparking parts inside. Do not use it in areas where gasoline, paint, or flammable vapors or liquids are used or stored.
11. Use this heater only as described in this manual. Any other use not recommended by the manufacturer may cause fire, electric shock, or injury to persons.

SAVE THESE INSTRUCTIONS

MODEL NUMBER DESIGNATION CHART				
SERIES	REFLECTOR PATTERNS	TAB HINGE	HOUSING MATERIAL	VOLTAGES
222	30	TH	BLANK = BROWN	208V
223	60			220V
342	90		SS= STAINLESS STEEL	240V
343	A30		A= ARCHITECTURAL ALUMINUM EXTRUSION	277V
462	A60			380V
463				480V

MODEL CONFIGURATION EXAMPLES:

222-30-TH-240V; 222 SERIES, 30° PATTERN, BROWN PAINTED HOUSING

342-60-THSS-277V; 342 SERIES, 60° PATTERN STAINLESS STEEL HOUSING

463-90-THA-480V; 463 SERIES, 90° PATTERN PAINTED ALUMINUM EXTRUSION HOUSING

REFLECTOR PATTERNS

30° Symmetric

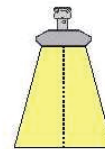

30° Asymmetric

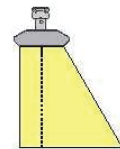

60° Symmetric

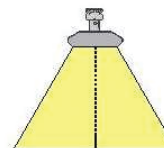

60° Asymmetric

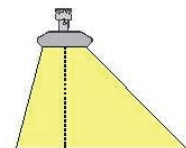

90° Symmetric

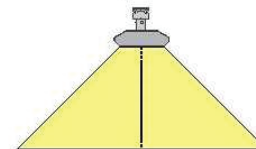

SPECIFICATIONS

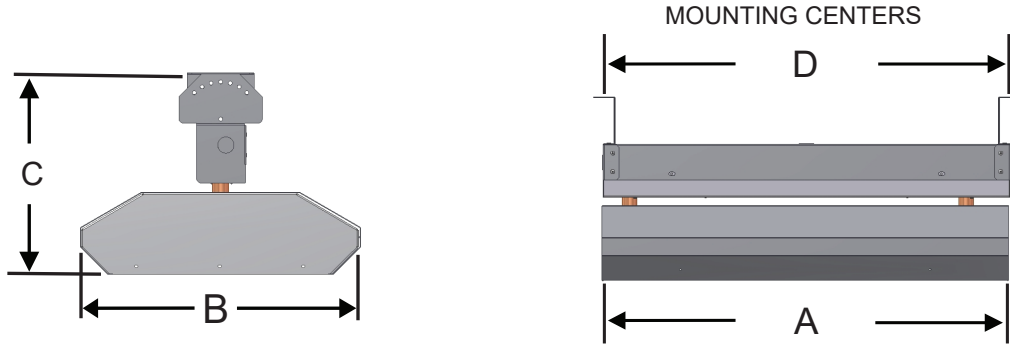

HEATER SERIES	NUMBER OF LAMPS	VOLTAGE and PHASE	WATTAGE	BTU'S	A	B	C	D
222	2	208; 1ph	3200	10,992	24"	15"	11"	23-1/2"
		240; 1ph						
		277; 1ph						
		480; 1ph						
223	3	208; 1 or 3ph	4800	16,382	24"	21-1/2"	11"	23-1/2"
		220; 1 or 3ph						
		240; 1 or 3ph						
		277; 1 or 3ph						
		380; 1 or 3ph						
		480; 1 or 3ph						
342	2	208; 1ph	5000	17,065	33"	15"	11"	32-1/2"
		240; 1ph						
		277; 1ph						
		480; 1ph						
		600; 1ph						
343	3	208; 1 or 3ph	7500	25,298	33"	21-1/2"	11"	32-1/2"
		240; 1 or 3ph						
		277; 1 or 3ph						
		480; 1 or 3ph						
		600; 1 or 3ph						
462	2	480; 1ph	7300	24,915	46"	15"	11"	45-1/2"
		600; 1ph	7600					
463	3	380; 1 or 3ph	10950	37,372	46"	21-1/2"	11"	45-1/2"
		480; 1 or 3ph						
		600; 1 or 3ph						

INSTALLATION PLANNING

The Fostoria Mul-T-Mount Series offers the highest watt density and heating efficiency in an electric infrared heater. All models are listed for spot-heat or total building heat indoors (excluding residential), or for totally unprotected outdoor applications. Fixtures are also listed for recessed applications, such as in ceilings or canopies.

2 and 3-Lamp models are available in either Stainless Steel , a Hi-Temp Brown Powder Coated or an Architectural extruded aluminum housing with powder coat finish.

The specially designed “T” Tab wire channel allows for one-man installation.

No asbestos or mercury is used in the manufacture of these heaters.

CHECKING YOUR SHIPMENT

Upon receipt of your shipment, check the carton(s) for damage.

Any accessory items ordered for heater will be shipped in their own carton.

Claims for damaged material or shortages that were not evident upon receipt of shipment must be reported to carrier and Fostoria customer service immediately.

Before starting to install the heater, make sure that all components and accessories ordered are available.

INSTALLER QUALIFICATIONS

Only firms or individuals qualified to perform work in accordance with the applicable specifications for electrical equipment should be engaged to install Fostoria MTM systems. Consult local building inspectors, fire marshals, your local Fostoria representative or the factory for guidance.

INSTALLER RESPONSIBILITY

National and local codes and ordinances together with specifications provided by Fostoria Industries comprise the information needed for proper installation. The installer must furnish all materials that have not been purchased from Fostoria Industries or its representatives. It is the installer's responsibility that the materials and methods of installation result in a job that is workmanlike and in keeping with all applicable codes.

In storage areas where stacking of materials may occur, the installer must provide signs which specify the maximum stacking height so as to maintain the required clearances to combustibles.

ELECTRICAL BONDING (GROUNDING)

A protective non-corrosive conductor terminal must be firmly attached to a protective bonding conductor (both supplied by customer). This must then be secured to the heater with the supplied green screw and lock washer in the heater wire-way to ensure a proper bond (ground).

LAYOUT DESIGN

When positioning heaters, keep in mind the clearance to combustible materials, lights, sprinkler heads, overhead doors, storage areas with stacked materials, gas and electrical lines, parked vehicles, cranes, etc. Refer to page eight (8) for minimum clearance to verify that a safe installation condition exists.

APPLICATION GUIDE

OUTDOOR COMFORT HEATING

Two (2) watts per square foot is equal to One (1) degree temperature rise. Heater installation shall comply with all OIPM, NEC, and local restrictions.

SPOT HEATING (OUTDOOR) APPLICATION CHART

MODEL SERIES	RECOMMENDED MOUNTING HEIGHT (FT.)	COVERAGE OF HEATHER LENGTH X WIDTH (FT.)	WATT PER SQUARE FOOT	TEMPERATURE RISE EXPECTED
222-60	8-10	10.5 X 9.5	32	15"
223-60	8-10	10.5 X 9.5	48	24"
342-60	10-12	14 X 12	30	15"
343-60	10-12	14 X 12	45	23"
462-60	10-12	15 X 12	41	20"
463-60	10-12	15 X 12	61	30"

INDOOR SPOT HEATING

One (1) watt per square foot is equal to One (1) degree temperature rise. When comfort spot heating people, two heaters should be used to heat both sides of the individual. Heater installation shall comply with all OIPM, NEC, and local restrictions.

SPOT HEATING (INDOOR) APPLICATION CHART

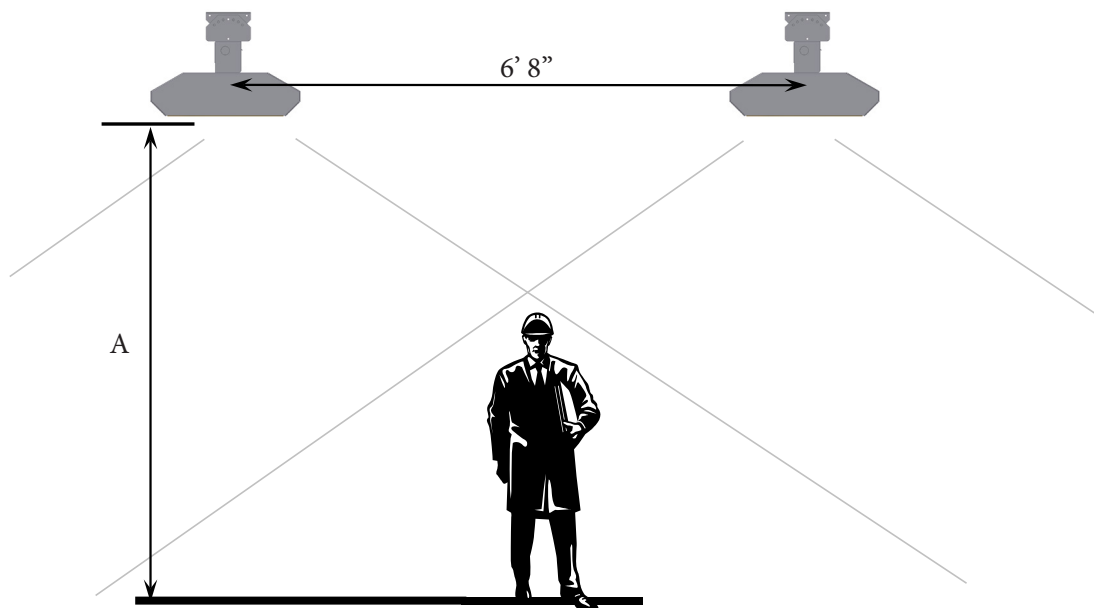

MODEL SERIES	RECOMMENDED MOUNTING HEIGHT (FT.) A*	COVERAGE OF HEATER LENGTH X WIDTH (FT.)	WATT PER SQUARE FOOT	TEMPERATURE RISE EXPECTED
222-60	8-10	13 X 12	21	20"
223-60	10-12	15 X 14	23	23"
222-30	12-14	8.5 X 7.5	50	50"
342-60	8-10	14 X 12	30	30"
343-60	10-12	16 X 14	24	34"
462-60	12-14	19 X 16	24	24"
463-60	12-14	19 X 16	36	36"

*Clearances to combustibles must be maintained regardless of recommended mounting height. See page 8 for clearance distances.



MINIMUM CLEARANCES TO COMBUSTIBLES

⚠ **WARNING**





**EXPLOSION HAZARD
FIRE HAZARD
BURN HAZARD**

- Serious injury or death may occur.
- Do not use in locations containing hazardous atmospheres.
- Do not touch any part of heater while in operation or directly thereafter. It is very HOT.

- Dimensions are listed in inches
- Dimension "B" indicates the required clearance to combustibles; it DOES NOT indicate the required mounting height.

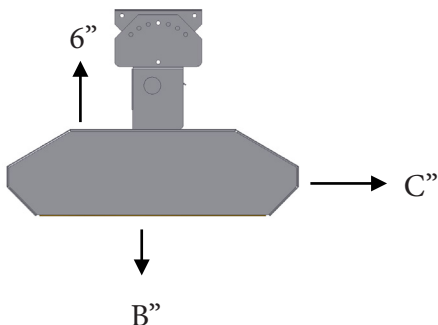
END VIEW – 0 DEGREE TILT



TOP VIEW - 2 UNITS SHOWN

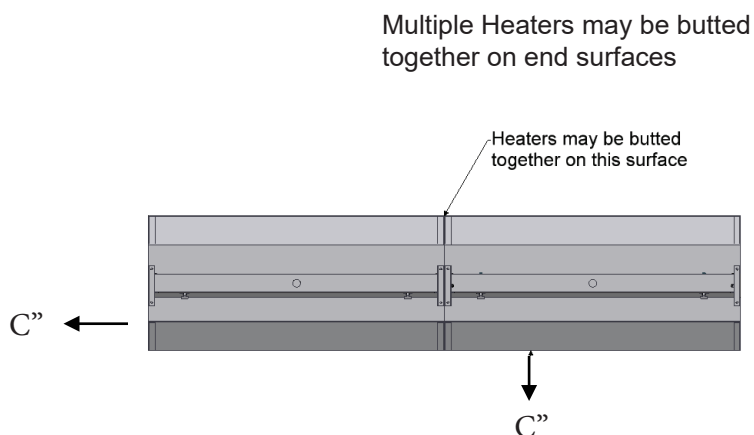

END VIEW – 0-45 DEGREE TILT

24" FROM A VERTICAL OR COMBUSTIBLE SURFACE

OR

36" FROM ANOTHER HEATER

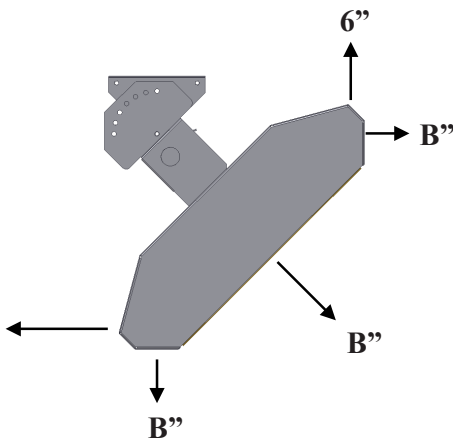

B" Dimension

2-Lamp units:
 -72" for a single unit
 -72" for (2) or more heaters being mounted end-to-end.

3-Lamp units:
 -72" for a single unit
 -96" for (2) or more heaters being mounted end-to-end.

C" Dimension

TYP. BOTH SIDES AND ENDS

24" FROM A VERTICAL OR COMBUSTIBLE SURFACE

36" FROM ANOTHER HEATER

WARNING!

Heaters should be installed so that the minimum clearance to vehicles, as marked on the heater, will be maintained. If vehicle lifts are present, ensure that the minimum clearance to combustibles will be maintained from the highest raised vehicle.

MOUNTING INSTRUCTIONS

CLEARANCES TO COMBUSTIBLES AS ON PAGE 8 OF THIS MANUAL AND ON THE HEATER MUST BE MAINTAINED AT ALL TIMES!

NOTE: If asymmetrical reflectors are used, be sure to mount the wireway with the “T” slots facing away from the wall or obstruction, and toward the area to be heated.

CAUTION: Install heater so that the quartz lamps are horizontal. Failure to do this may cause the heating element within the tube to sag and cause premature burnout.

Mounting Centers

Heater Series	“A” dimension
222 & 223	23-1/2
342 & 343	32-1/2
462 & 463	45-1/2

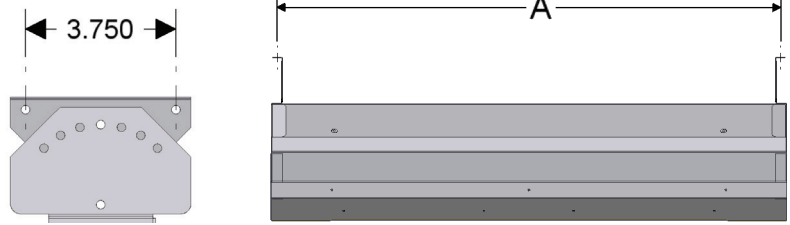

Figure A

Top channel assembly

1. Attach the adjustment hanging brackets to the top wire channel. On each end, place (1) 10-32 x 1/2" screw through the bottom hole of the adjustment hanging bracket and through the bottom hole of the top wire channel. Place (1) 10-32 lock nut on the screw. Don't tighten completely. **NOTE:** The adjustment hanging brackets are **NOT** required for chain suspension.
2. Adjust bracket to desired mounting angle (see figure B).
3. Place (1) 10-32 x 1/2" screw through the slot in the adjustment hanging bracket and the hole in the top wire channel. Place (1) 10-32 lock nut on the screw and tighten.
4. Tighten 10-32 lock nuts from step #1.
5. Hook heater body into mounted wire channel cover. Unit will hang freely by the “T” tabs, leaving both hands free to wire unit (see figure C).
6. Close wire channel using the (4 or 6) 8-32 x 3/8 screws provided in hardware pack. **NOTE:** Quantity will vary depending on heater length.

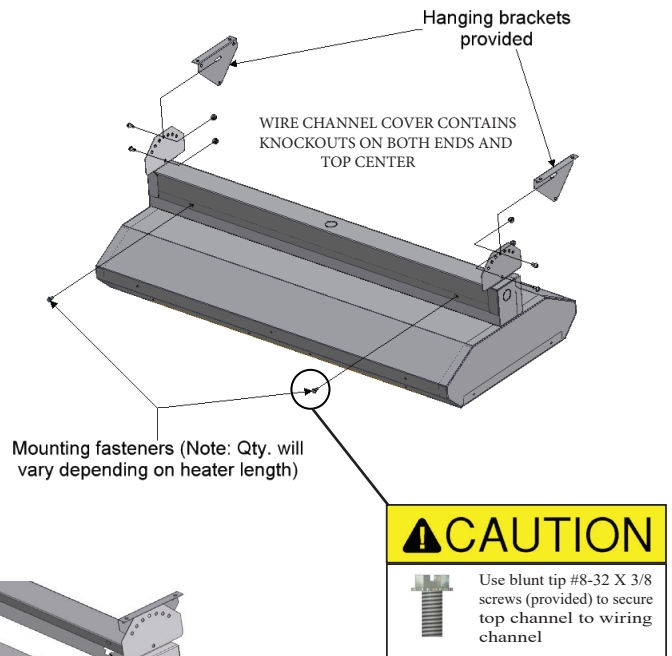

Figure C

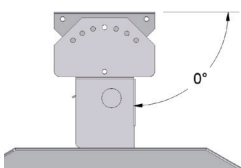
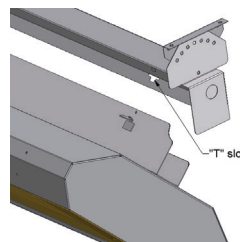
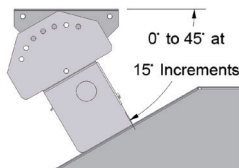

Figure B



MOUNTING OPTIONS

CHAIN SUSPENSION: Use 14 gauge jack chain and “S” hooks (not supplied). “S” hooks must be crimped shut so the heater cannot be inadvertently lifted off of its mounting.

***NOTE – 462 & 463 Series heaters are not designed for chain suspension. One of the three mounting options to the right should be used for these heaters.**

STEM SUSPENSION: Use solid rods (1/4" diameter min.) or suitable tubing. Drill holes in top wire channel 4" from each end for mounting.

VMB-41-SS: Wall Mounting Bracket.

RECESSED MOUNTING: Refer to page 14 of this manual.

MOUNTING INSTRUCTIONS

Extended mounting bracket sold with bundled units.

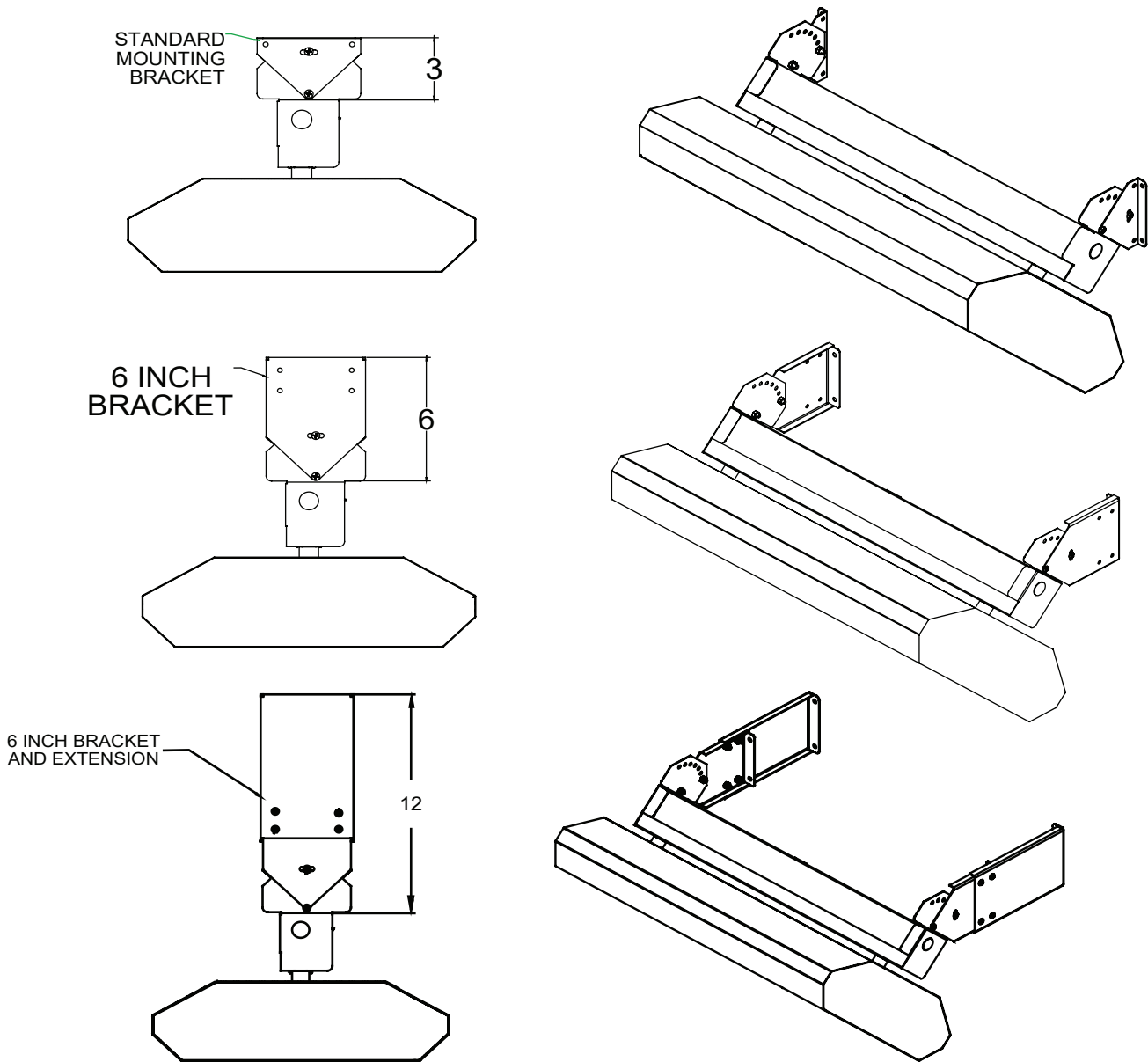

DESCRIPTION

The extended bracket kit is an accessory that adds versatility to the mounting capability of the Multi-Mount series infrared heaters. The extended brackets provide for additional mounting clearance for ceiling or wall mounting. The bracket kit has a 6 inch bracket that can be used alone or with the extension for 12 inches of clearance. These brackets are optional. The standard 3 inch bracket can be used or any other sufficient means that provides the minimum mounting clearances stated in the manual.

ASSEMBLY

All hardware necessary for mounting the optional brackets to the heater is provided in the kit. The brackets provide for angular rotation up to 45° for direction of radiation. Hardware necessary for mounting to structure is provided by installer. Mounting hardware must be suitable for the surface the heater is mounted to. The surface and hardware must be capable of supporting the total weight of the heater and brackets.

TOTALLY EXPOSED OUTDOOR APPLICATIONS

For totally exposed outdoor applications (not ceiling protected) the connections must be made as illustrated at right.

CAUTION

Red sleeves used for visible light reduction are not recommended for applications near coastal waters. Purchase lamps with integral light filter from factory for these applications.

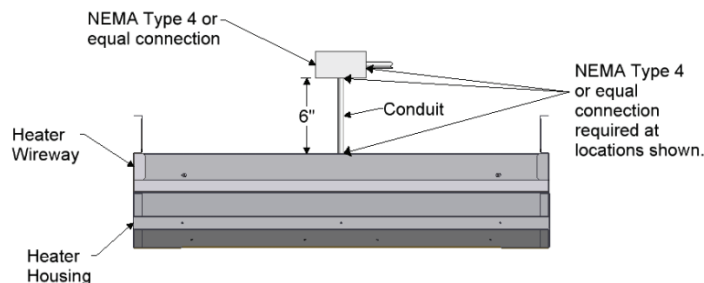

Note: All conduit, conduit fittings and junction boxes are supplied by the customer.

LAMP INSTALLATION & REPLACEMENT

CAUTION: Disconnect power before installing or replacing supplied quartz lamps or quartz tubes. These elements can and should be installed prior to mounting heater.

1. Remove the housing end caps and open positioning clips.
2. Position heating elements in "L" slots at ends of reflector. Avoid handling quartz glass as much as practical. Quartz glass should be wiped off with a clean cloth before energizing heater.
3. Close positioning clips to secure the heating element in the slot (see figure A).
4. Carefully wrap heating element pigtail clockwise around terminal screws (see figure B).
5. Tighten terminal screws (see figure B). **CAUTION:** Do not draw pigtail so tight that pressure is put on heating element. **Maintain a partial loop (or looseness) in the pigtail 1/2" max. see FIGURE B.**
NOTE: Cut excess pigtail off at terminal to prevent lead from touching metal parts.
6. Install end caps using sheet metal screws supplied in parts kit.

FIGURE A

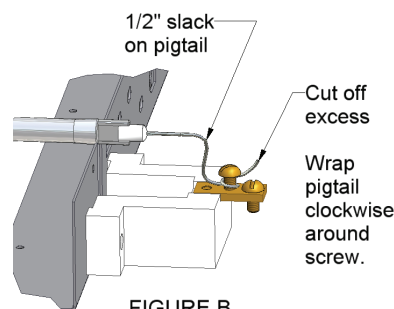
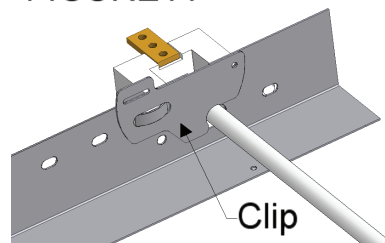

FIGURE B

⚠ WARNING

POSSIBLE LAMP FAILURE

The heating elements used in this product can be damaged by contamination (salt deposits from perspiration or coastal air) on the surface of the quartz sleeve. At high temperatures, these salts will cause the quartz to become porous and leak, allowing air to come in contact with the tungsten element. When this occurs, the element will burn out quickly and the outer quartz sleeve can break. The instructions below must be followed.

- Always wear cotton or latex gloves when installing or replacing elements.
- Always clean the quartz sleeve with an alcohol moistened soft cloth before using the heater
- Whenever contamination (milky white appearance on quartz sleeve) is observed, the element must be immediately replaced.

WIRING FOR UNITS WITH (2) LAMPS

⚠ WARNING

ELECTRICAL SHOCK HAZARD

- **Serious injury or death may occur.**
- **Disconnect from electrical supply before installing or servicing this heater.**
- **This appliance must be connected to a properly bonded (grounded) electrical source.**



This fixture is equipped with 4 high-temperature silicone lead wires to accommodate either single phase or three phase electrical service. They are shipped wire-tied together. Remove the wire-tie before making electrical connections.

Wiring connections should always be made through one of the knockouts in the top wire channel. Consult the factory, or a qualified electrician for details on staging.

Wires in wiring channel are identified with wire markers. **Markers indicate lamp number.**

Supply wires must be copper and rated for at least 90° C. Wire connectors should also have a minimum rating of 90° C.

For use in TOTALLY EXPOSED OUTDOOR APPLICATIONS refer to page 10.

SINGLE-STAGE WIRING Connect both wires from one end of heater to L1 and the remaining wires from the other end to L2 in the control panel.

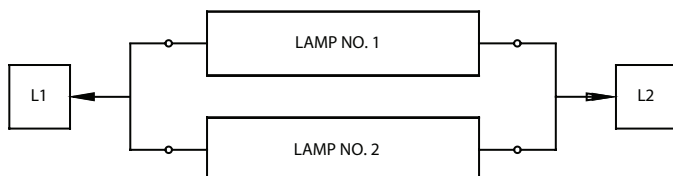

TWO-STAGE WIRING

Two-stage operation allows one or both lamps in the heater(s) to be energized, depending on the signal from an appropriate two-stage control device (e.g. two-stage thermostat). This will allow the heater(s) to operate at 50% on, 100% on, or 100% off; instead of limiting the operation to 100% on or 100% off.

Two circuits are required for two-stage wiring.

For two-stage operation connect L1 & L2 of circuit #1 to lamp #1 and connect L1 & L2 of circuit #2 to lamp #2 as illustrated below.

CIRCUIT #1

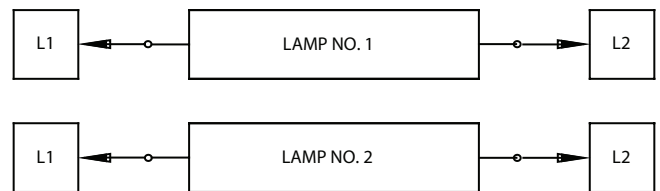

CIRCUIT #2

Common component layout for controlling
Fostoria Mul-T-Mount heaters
(2 Stage wiring shown)
This is NOT a wiring schematic

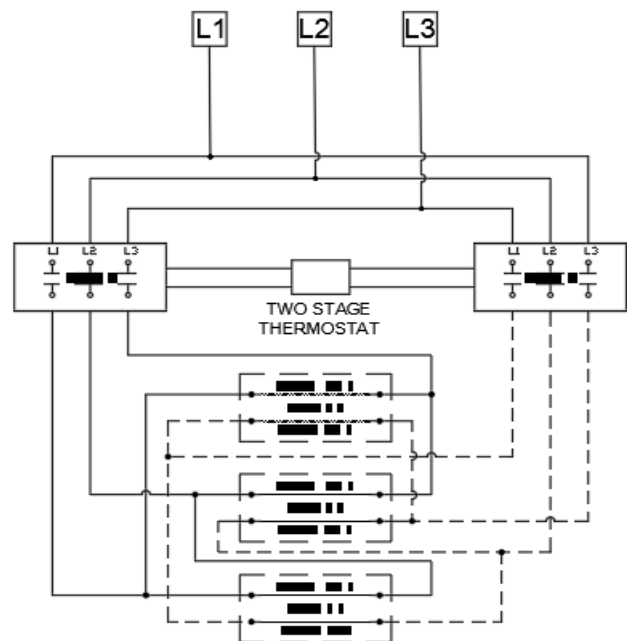

WIRING FOR UNITS WITH (3) LAMPS

⚠ WARNING

ELECTRICAL SHOCK HAZARD

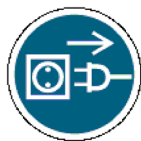

- **Serious injury or death may occur.**
- **Disconnect from electrical supply before installing or servicing this heater.**
- **This appliance must be connected to a properly bonded (grounded) electrical source.**

This fixture is equipped with 6 high-temperature silicone lead wires to accommodate either single phase or three phase electrical service. They are shipped wire-tied together. Remove the wire-tie before making electrical connections.

Wiring connections should always be made through one of the knockouts in the top wire channel. Consult the factory, or a qualified electrician for details on staging. Refer to Figure A on page 9.

Supply wires must be copper and rated for at least 90° C. Wire connectors should also have a minimum rating of 90° C.

For use in TOTALLY EXPOSED OUTDOOR APPLICATIONS refer to page 10.

SINGLE PHASE, SINGLE STAGE WIRING

Connect all three wires from one end of heater to L1 and the remaining three wires from the other end to L2; refer to diagram below.

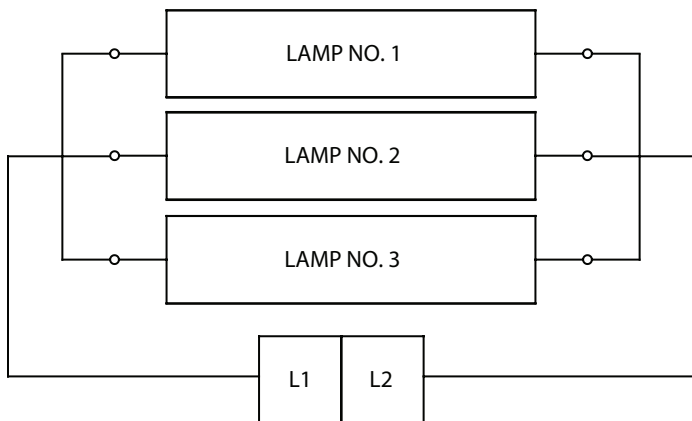

Control Panel

TYPICAL SINGLE PHASE WIRING

Wire markers on lead wires indicate lamp number

THREE PHASE, SINGLE STAGE WIRING

Balance each leg throughout the three elements in each heater, as shown below.

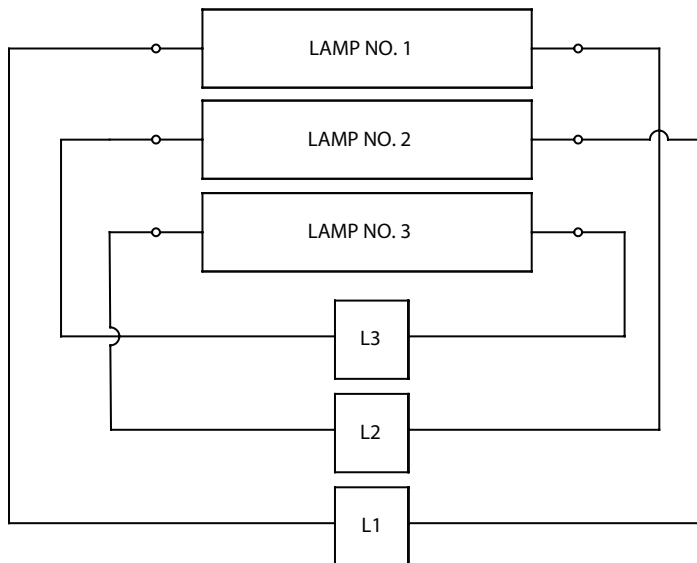

Control Panel

TYPICAL THREE PHASE WIRING

Wire markers on lead wires indicate lamp number

MAINTENANCE

Pre-Season Maintenance and Annual Inspection

To ensure your safety and for years of trouble-free operation of the heating system, annual service and inspections must be done by a qualified contractor.

To obtain maximum performance from your heater(s) each year, we recommend the following be performed at the start of the heating season:

1. Clean reflector surface with a damp cloth.
2. Clean quartz lamp with alcohol moistened soft cloth.
3. Make sure heater is secure on all hanging points.
4. **Maintain the Clearance to Combustibles.** Immediately remove objects in violation of the clearance to combustibles.

If additional service to the heater is required, contact the factory or your local representative.

TROUBLESHOOTING

SYMPTOM	POSSIBLE CAUSE(S)	CORRECTIVE ACTION
Element does not energize	<ol style="list-style-type: none">1. Defective element.2. Improper connection.3. Pigtail loose from socket connection.	<ol style="list-style-type: none">1. Replace element.2. Check connection to power source.3. Rewind or re-insert pigtail into socket.
Not enough heat.	<ol style="list-style-type: none">1. Heater too small for application.2. Heater mounted too high or too far.	<ol style="list-style-type: none">1. Add more heaters.2. Decrease mounting height or distance.
Too much heat.	<ol style="list-style-type: none">1. Heater too large for application.2. Heater mounted too low or too close.	<ol style="list-style-type: none">1. Replace with smaller heater.2. Increase mounting height or distance.

WARNING: WHEN ADJUSTING MOUNTING HEIGHT FOR MORE OR LESS HEAT, STAY WITHIN RECOMMENDED MOUNTING HEIGHTS ON PAGE 7.

OPTIONAL RECESSED MOUNTING FRAME INSTALLATION

MOUNTING INSTRUCTIONS 'TH' AND 'THSS' MODELS ONLY

1. Mount frame to heater with #8 x 1/2" long sheet metal screws supplied by customer. Four screws are required on the RMF-222-A, six required on the RMF-342-A and eight on the RMF-462-A and RMF-223-SS units; ten screws are required on the RMF-343-SS and twelve on the RMF-463-SS models. Use the frame as a template for laying out the holes.
2. Mount the frame to the ceiling, using the outside slots only, with 1/4" lag screws provided by the customer. Four lag screws are required on the RMF-222-A and RMF-223-SS units, six on the RMF-342-A and RMF-343-SS, and eight on the RMF-462-A and RMF-463-SS units. Tabs will center frame in opening. **CAUTION: To maintain required clearance above heater, refer to minimum clearances to combustible on page 8.**

FIELD WIRING CONNECTIONS

- A. Select the appropriate knockout on the top wiring channel, and install a 12" conduit nipple and splice box (customer supplied).
- B. Route the leads from the wiring channel through the conduit and connect with the supply wiring inside the splice box.
- C. Follow local and national electric codes.

NOTE: Hold dimensions A and B to + 1/8" for rough opening in the ceiling.

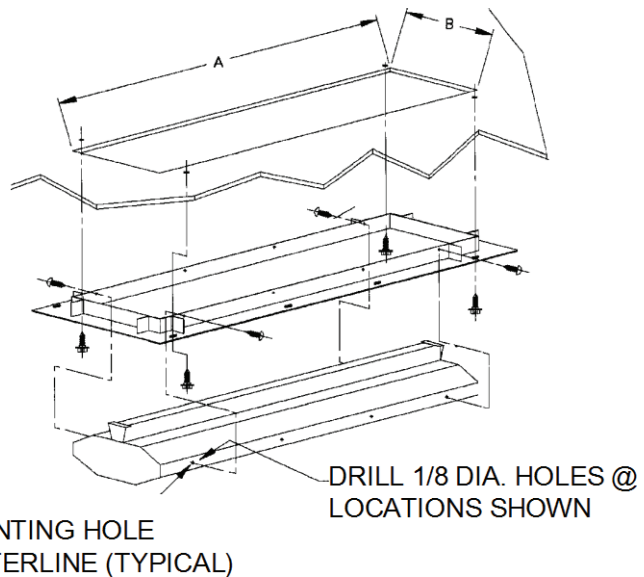

Heater Series		Model	Part No. D	DIM. A (IN.)	DIM B (IN.)
222	Painted	RMF-222-A	04494402	27 1/4	18
	Stainless	RMF-222-SS-A	04419902		
342	Painted	RMF-342-A	04418702	36 1/4	
	Stainless	RMF-342-SS-A	04420702		
462	Painted	RMF-462-A	04494502	49 1/4	
	Stainless	RMF-462-SS-A	04421002		
223		RMF-223-SS	08811039	32 1/4	29 5/8
343		RMF-343-SS	08811339	41 1/4	
463		RMF-463-SS	08811139	54 1/4	

OPTIONAL WIRE GUARD INSTALLATION MODELS TH AND THSS

Heater Series	Wire Guard	Part Number
222	CHWG-222	08511500
223	CHWG-223	08543600
342	CHWG-342	08511400
343	CHWG-343	08543500
462	CHWG-462	08516200
463	CHWG-463	08543400

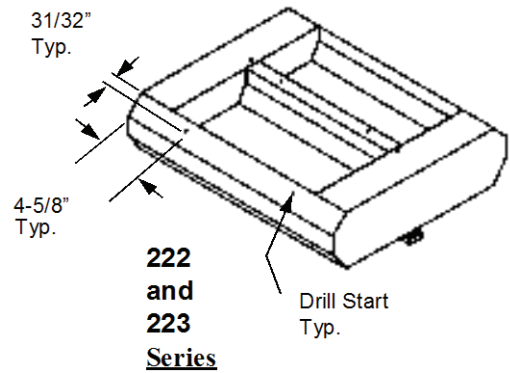

CAUTION: DISCONNECT POWER BEFORE INSTALLING OR SERVICING. IF THE POWER DISCONNECT IS OUT OF SIGHT, LOCK IT IN THE OPEN POSITION AND TAG IT TO PREVENT UNEXPECTED APPLICATION OF POWER. FAILURE TO DO SO COULD RESULT IN FATAL ELECTRICAL SHOCK.

Mounting holes for attaching the lamp guard are provided in heater housing. NOTE: Mounting holes are not provided on older models. Using the drill starts provided in the heater housing, drill a 1/8" diameter hole at each location. (See dimensional details.)

1. Place mounting clips provided, on the loops of the lamp guard (see Detail A below).
2. Attach the lamp guard to the heater using the #8 sheet metal screws provided.

MAINTENANCE

CAUTION: Disconnect power before installing or servicing. If the power disconnect is out of sight, lock it in the open position and tag it to prevent unexpected application of power. Failure to do so could result in fatal electrical shock.

To service the heater in the overhead position, it will be necessary to remove the screws from only one side of the lamp guard. The lamp guard will then swing clear of the heater.

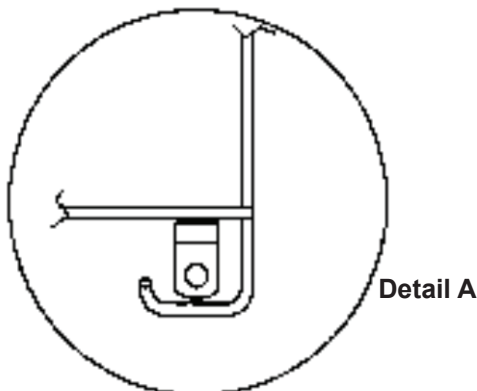

OPTIONAL WIRE GUARD INSTALLATION 'THA' MODELS

1. Slide wire guard into track on the bottom of the extrusion.
2. Secure wire guard with the provided screw(s) into the end cap of the heater, being careful not to strip screws.

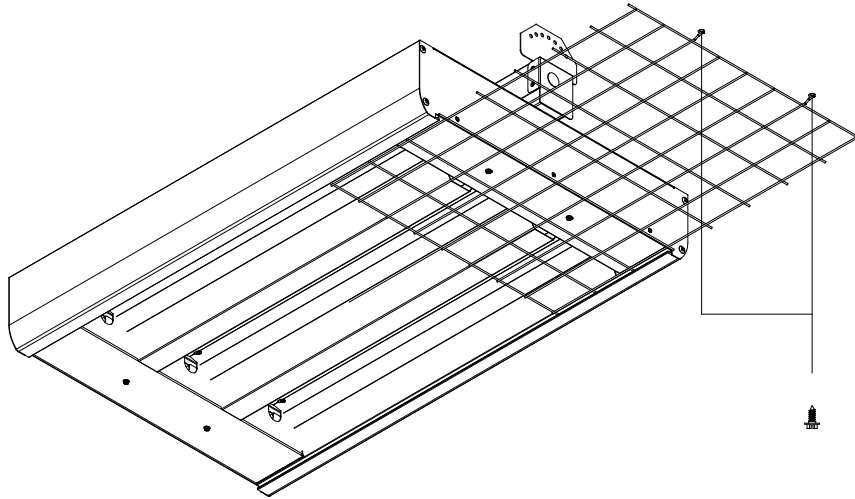

Optional Wire Guards For 'THA' Series

Heater Series	Wire Guard	Part Number
222	THA-222	04898602
223	THA-223	04898702
342	THA-342	04898802
343	THA-343	04898902
462	THA-462	04899002
463	THA-463	04899102